



NEW ITEMS 2009

ADDITION TO PRODUCT RANGE N° 15

*Designed & Manufactured
Exclusively in Italy*

SCOOTER 50 2T

MALAGUTI		Type	EXTRA	Cr EXTRA
			HOMOLOGATED	HOMOLOGATED
			Code	Code
F12 R PHANTOM air '07-09		83 var. 02 ver. A1 / B1	31256P	
F12 R PHANTOM air '07-09		83 var. 02 ver. 01	31259P	

MALAGUTI		Type	REVERSE	GO!
			HOMOLOGATED	HOMOLOGATED
			Code	Code
F12 R PHANTOM air '07-09		83 var. 02 ver. A1 / B1	31255E	31254R
F12 R PHANTOM air '07-09		83 var. 02 ver. 01	31260E	31258R

SCOOTER MAXI

PIAGGIO		Type	FREE WAY	IPERSCOOTER
			Code	Code
VESPA GTS 300 i.e. '08-09				52611IP

ENDURO 2T



Omologazione Europea (norm. 97/24/CEE cap. 9)
European Road Approval (directive 97/24/EC cap.9)

N.B. - NOTE

L'omologazione è valida soltanto per i type del veicolo specificati
Road approved certification is valid for specified vehicle types only.

intercambiabili con l'originale
interchangeable with stock one



APRILIA		Type	Homol.	Marmitta Exhaust	Homol.	aluminium silencer	Homol.	Carbon fibre silencer
				Code		Code		Code
RX 50 '06-09 (Piaggio engine)		PV var.0 ver.00		34078HF	e	34683HF	e	34684HF
SX 50 '06-09 (Piaggio engine)		PV var.A ver.00		34078HF	e	34683HF	e	34684HF
SX 125 '08 (11Kw)		RV var.0 ver.00		54057HF	e	54658HF		54059HF
DERBI		Type		Code		Code		Code
SENDA 50 R Xrace/Xtreme '09		SR2D1B / SR2D2B		34078HF	e	34683HF	e	34684HF
SENDA 50 SM Xrace/Xtreme '09		SR2D1A / SR2D2A		34078HF	e	34683HF	e	34684HF
HM		Type		Code		Code		Code
CRE 50 Baja / Derapage '03-09		50 S var. AM ver. E		34079HF	e	34685HF	e	34686HF
		50 S var. AM ver. M - 50X var. AC ver. E - 50X var. AL ver. E						
CRE 50 Baja RR / DerapageRR '06-09		50X var. AC ver. E/M		34080HF	e	34685HF	e	34686HF
CRE 50 Six Competition '06-09		50X var. AL ver. E		34080HF	e	34685HF	e	34686HF
Derapage 50 Competition '06-09		50X var. AL ver. M		34080HF	e	34685HF	e	34686HF



Slip-on



catalytic mid-pipe

	Carby end cap	Steel end cap	
Titanium	73750T6SY	73750T6S	
Carbon fibre	73750C6SY	73750C6S	71510CT*
Nichrom		73750X6S	
Aluminium		73750A6S	* Not to be used with carbon fibre silencers



Slip-on



Full system (racing collectors)

	Carby end cap	Steel end cap	Carby end cap	Steel end cap
Titanium	73751T6Y	73751T6		
Carbon fibre				
Nichrom		73751X6		
Aluminium		73751A6		



Slip-on

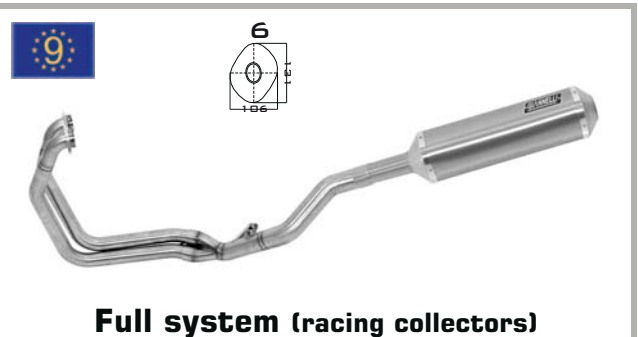

Full system (racing collectors)

	Carby end cap	Steel end cap	Carby end cap	Steel end cap
Titanium	73751T6Y	73751T6	73751T6KY	73751T6K
Carbon fibre				
Nichrom		73751X6		73751X6K
Aluminium		73751A6		73751A6K

European Homologation for catalytic converter only **directive 97/24/EC ch. 5** (measures to be taken against air pollution caused by 2 or 3 wheel motor vehicles)

European Homologation for silencer only **directive 97/24/EC ch. 9** (permissible sound level and exhaust system for 2 or 3 wheel motor vehicles)



Meets **2006/120/EC** European Directive standards (**97/24/EC ch. 9 + ch.5** European Directive upgrade).
European standards are met only if: the original catalytic converter is not removed when fitting an **9/24/EC ch.9** approved Giannelli Silencer or if you fit a Giannelli exhaust system with an approved (as per **97/24/EC ch.5** standard)catalytic converter

BMW



F 800 S - ST '06/09

TYPE: EBST var. 0216 ver. A - EBST var. 0234 ver. A



Slip-on

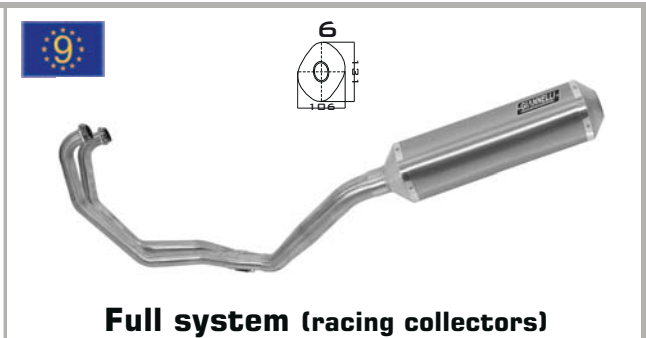

Full system (racing collectors)

	Carby end cap	Steel end cap	Carby end cap	Steel end cap
Titanium	73752T6Y	73752T6	73752T6KY	73752T6K
Carbon fibre				
Nichrom		73752X6		73752X6K
Aluminium		73752A6		73752A6K

BMW



F 800 R '09

TYPE: EBST var. 0217 ver. A



Slip-on

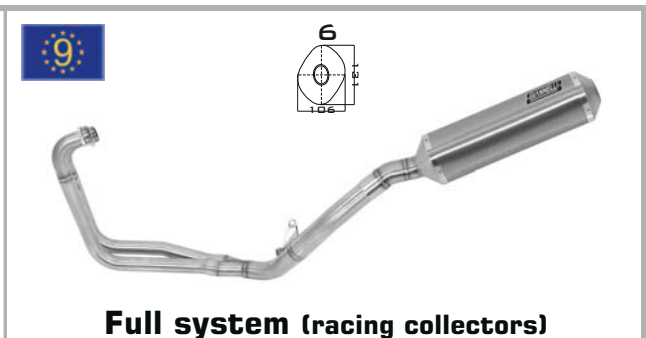

Full system (racing collectors)

	Carby end cap	Steel end cap	Carby end cap	Steel end cap
Titanium	73753T6Y	73753T6	73753T6KY	73753T6K
Carbon fibre				
Nichrom		73753X6		73753X6K
Aluminium		73753A6		73753A6K

BMW

R 1200 R '06/09

TYPE: R1ST var. 0378 ver. A



Slip-on



Full system

	Carby end cap	Steel end cap	Carby end cap	Steel end cap
Titanium	73754T6Y	73754T6		
Carbon fibre				
Nichrom		73754X6		
Aluminium		73754A6		

European Homologation for catalytic converter only directive 97/24/EC ch. 5 (measures to be taken against air pollution caused by 2 or 3 wheel motor vehicles)

European Homologation for silencer only directive 97/24/EC ch. 9 (permissible sound level and exhaust system for 2 or 3 wheel motor vehicles)



Meets 2006/120/EC European Directive standards (97/24/CE ch. 9 + ch.5 European Directive upgrade). European standards are met only if: the original catalytic converter is not removed when fitting an 9/24/EC ch.9 approved Giannelli Silencer or if you fit a Giannelli exhaust system with an approved (as per 97/24/EC ch.5 standard)catalytic converter



Full System (racing collectors)

catalytic mid-pipe

Titanium	73749T6K
Carbon fibre	
Nichrom	73749X6K
Aluminium	73749A6K

	71509CT*
--	-----------------



Slip-on

Full system

Titanium	
Carbon fibre	
Nichrom	
Aluminium	74614AL

	74614ALK
--	-----------------



Slip-on

Full System (racing)

Carby end cap

Steel end cap

Carby end cap

Steel end cap

Titanium	73756T6Y	73756T6
Carbon fibre		
Nichrom		73756X6
Aluminium	73756A6	73756A6
GX-One		73419GX

	73350T6KY	73350T6K
	73350C6KY	73350C6K
		73350X6K
		73350A6K

European Homologation for catalytic converter **only directive 97/24/EC ch. 5** (measures to be taken against air pollution caused by 2 or 3 wheel motor vehicles)

European Homologation for silencer **only directive 97/24/EC ch. 9** (permissible sound level and exhaust system for 2 or 3 wheel motor vehicles)

Meets **2006/120/EC** European Directive standards (**97/24/EC ch. 9 + ch.5** European Directive upgrade). European standards are met only if: the original catalytic converter is not removed when fitting an **9/24/EC ch.9** approved Giannelli Silencer or if you fit a Giannelli exhaust system with an approved (as per **97/24/EC ch.5** standard)catalytic converter



Slip-on

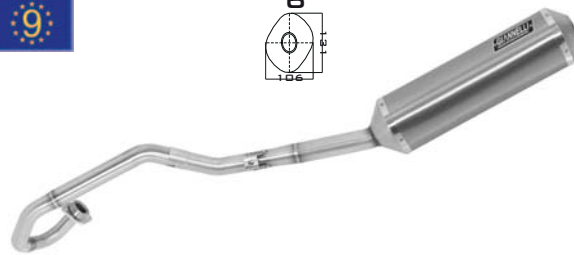

Full system (racing collectors)

Carby end cap

Steel end cap

Carby end cap

Steel end cap

Titanium	73755T6Y	73755T6	73755T6KY	73755T6K
Carbon fibre				
Nichrom		73755X6		73755X6K
Aluminium		73755A6		73755A6K



European Homologation for catalytic converter only **directive 97/24/EC ch. 5**
(measures to be taken against air pollution caused by 2 or 3 wheel motor vehicles)



European Homologation for silencer only **directive 97/24/EC ch. 9**
(permissible sound level and exhaust system for 2 or 3 wheel motor vehicles)



Meets **2006/120/EC** European Directive standards
(**97/24/EC ch. 9 + ch.5** European Directive upgrade).

European standards are met only if: the original catalytic converter is not removed when fitting an **9/24/EC ch.9** approved Giannelli Silencer or if you fit a Giannelli exhaust system with an approved (as per **97/24/EC ch.5** standard) catalytic converter



Via Gonzaga 12/14 - 06016 San Giustino (PG) - Italy
Tel. +39-075-861081 Fax +39-075-8582925
info@giannelli.com www.giannelli.com